

OK-VISE®

Grid Fixturing System

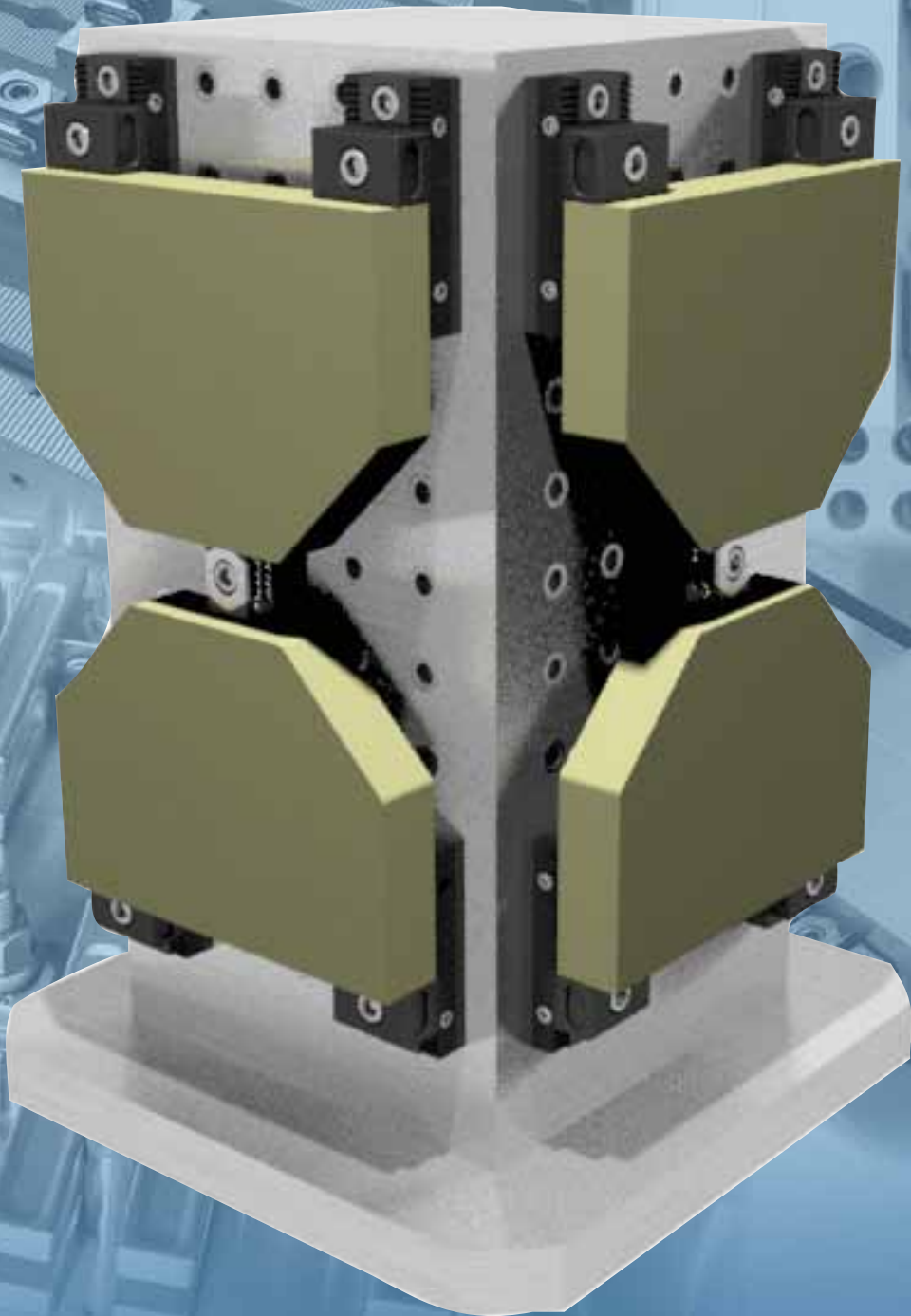

GENERIC FIXTURING COMPONENTS

GRID FIXTURING SYSTEM

Grid Fixturing System is the new generic-purpose fixturing system from OK-VISE.

It can be adapted to the grid platforms of leading workholding suppliers. With the OK-VISE Grid Fixturing System very complex forms of workpieces can be also clamped.

On a grid platform you can also combine OK-VISE modules with the components of other suppliers.

GRID SYSTEM COMPONENTS

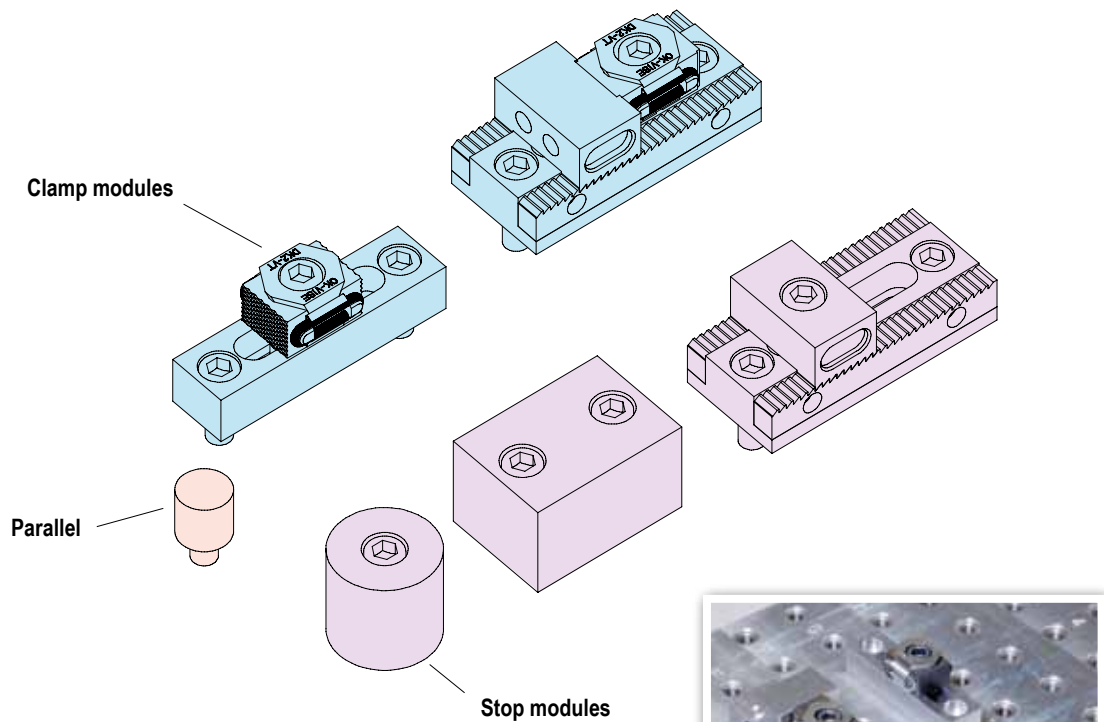

Clamp module

GCD-DR1	Serrated jaws, D-series
GCD-DS1	Smooth jaws, D-series
GCD-BR1	Serrated jaws, B-series
GCD-BS1	Smooth jaws, B-series
GCS-DS1	Adjustable, Smooth D-series jaw
GCS-DR1	Adjustable, Serrated D-series jaw

Stop module

GS-SF1	Round, smooth
GS-SF2	Rectangular, fixed, smooth
GS-SA1	Adjustable, smooth
GR-RF1	Round, serrated
GR-RF2	Rectangular, fixed, serrated
GR-RA1	Adjustable, serrated

Parallel

GP-1	Round
------	-------



More info: <http://www-ok-vise.com/grid-system/>

GRID SYSTEM APPLICATIONS

To make selection of the components easier, the OK-VISE team has selected some basic sets to enable an easy start with the Grid system. In the pictures below you can see the solutions done with each set. We recommend platforms of leading suppliers. Grid plate is normally not included in the set.

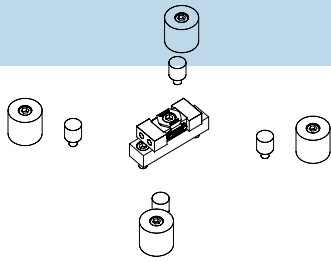

SG-Z01

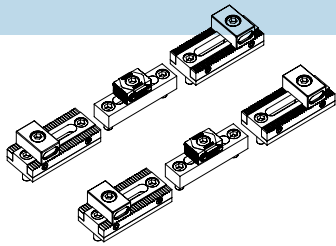
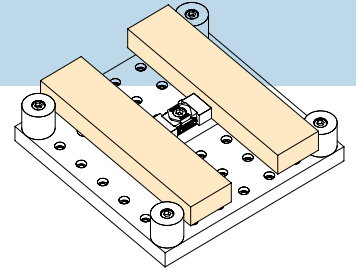
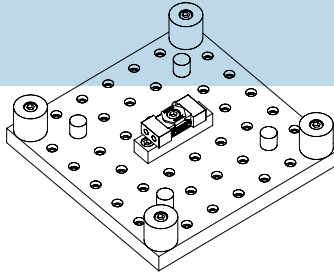

SG-Z02

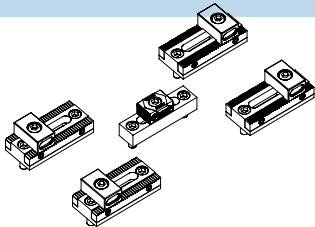
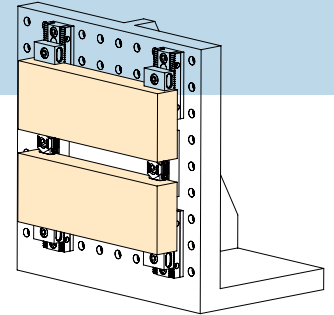
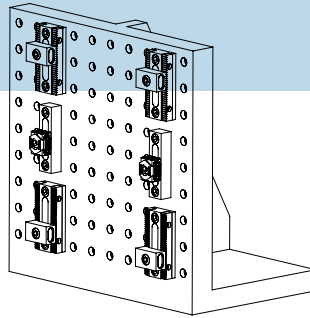

SG-Z03

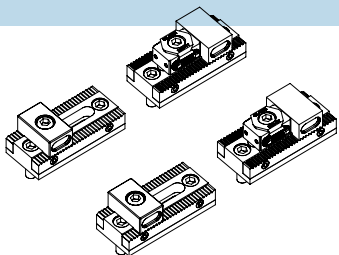
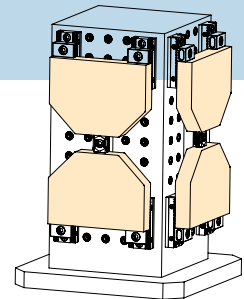
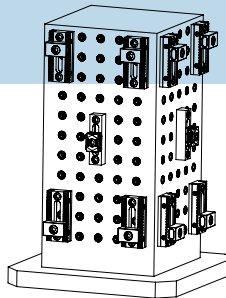

SG-Z04

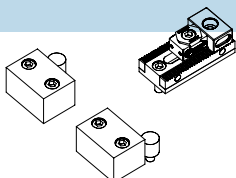
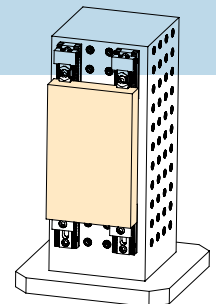
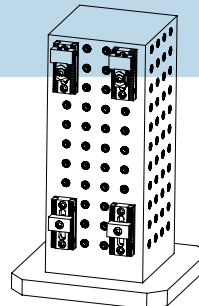

SG-Z05

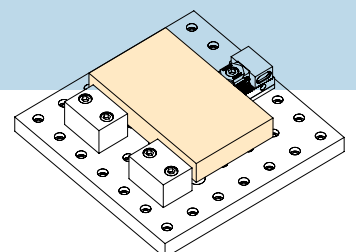
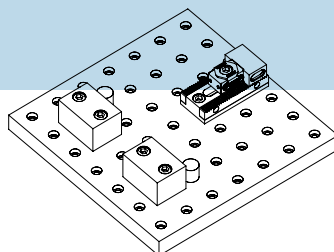

OK-VISE FIXTURING CONCEPT

All platforms, all workpieces

GENERIC FIXTURING COMPONENTS

Multi-Rail RM System



Multi-Rail RH System



Combo-Rail



Grid Fixturing System



LOW-PROFILE CLAMPS

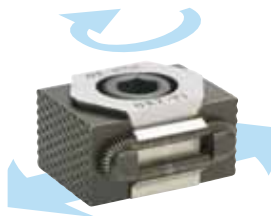

OK-VISE[®]
Clamping Method

COMPONENTS FOR DEDICATED FIXTURING

Blank Fixturing System



The original OK-VISE low-profile clamps are known worldwide as a core component of any modern workholding system. In the machining industry, OK-VISE name means quality.

The mother company of OK-VISE OY is Kytola Instruments. The company is known for manufacturing precision instruments.
www.kytola.com



MANUFACTURER

DISTRIBUTOR

OK-VISE[®]

OK-Vise Oy, P.O.Box 5
40951 Murame, Finland
Tel. 020 7790 699, Fax (014) 631 419
Technical questions: support@ok-vise.com
www.ok-vise.com