

Lathe Machine Reducing Change Tool Sleeve (Straight style)

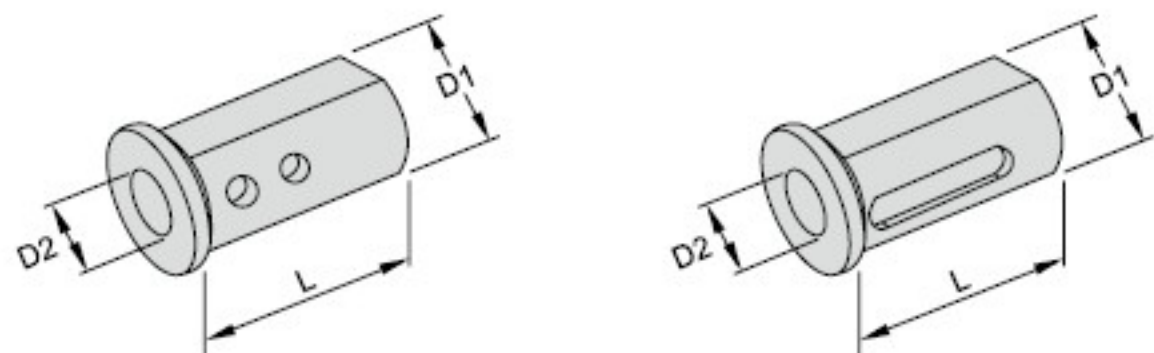

Code No.	External Dia D	Clamping Length L	Front End Length	Total Length	Internal Dia d
D20-6/8/10/12/16	D20	45	5	50	6/8/10/12/16
D25-6/8/10/12/16/20	D25	55	5	60	6/8/10/12/16/20
D32-6/8/10/12/16/20/25	D32	60	5	65	6/8/10/12/16/20/25
D40-6/8/10/12/16/20/25/32	D40	70	5	75	6/8/10/12/16/20/25/32
D50-6/8/10/12/16/20/25/32/40	D50	85	5	90	6/8/10/12/16/20/25/32/40

Lathe Machine Reducing Change Tool Sleeve (Morse Drill style)

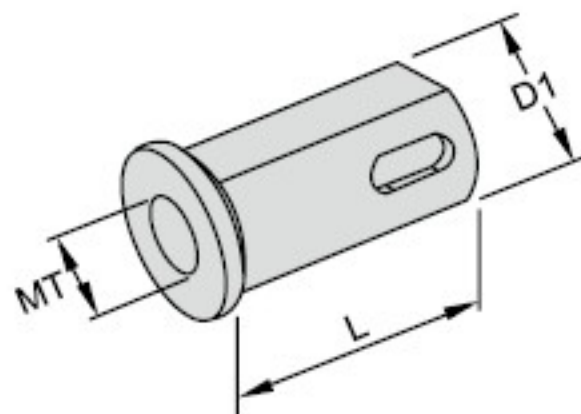

Code No.	External Dia D	Clamping Length L	Front End Length	Total Length	Internal Dia d
D20-MTA1	D20	50	15	65	5
D20-MTA2	D20	50	25	75	5
D25-MTA1	D25	50	15	65	5
D25-MTA2	D25	50	25	75	5
D25-MTA3	D25	50	45	95	5
D32-MTA1	D32	60	5	65	5
D32-MTA2	D32	60	15	75	5
D32-MTA3	D32	60	35	95	5
D40-MTA1/MTA2	D40	75	5	80	5
D40-MTA3	D40	75	20	95	5
D50-MTA1/MTA2/MTA3	D50	85	5	90	5
D50-MTA4	D50	85	35	120	5

Tool Holder

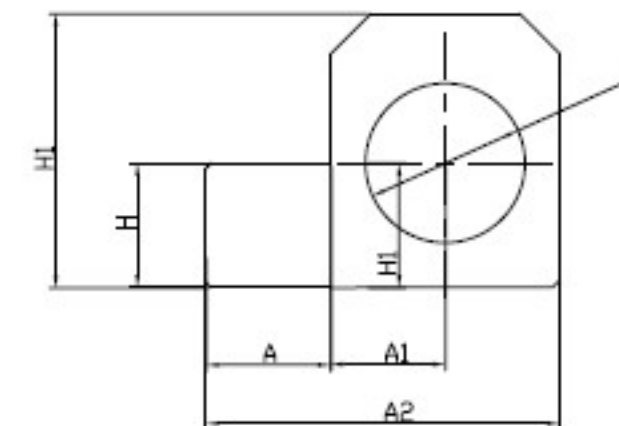
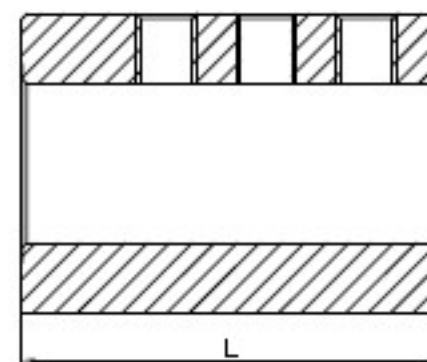
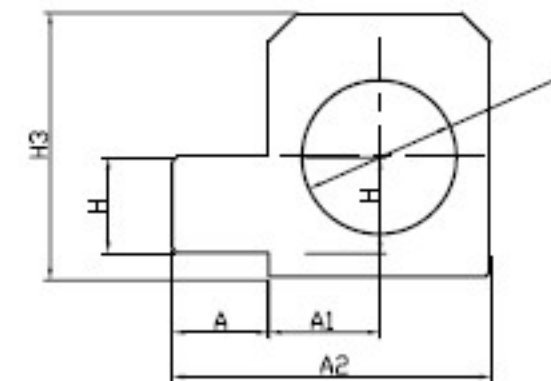
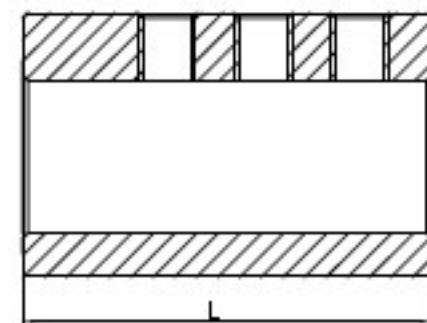

Code No.	H1	H	A	A1	L	D
HTD2020-32	20	20	20	24	80	32
HTD2525-40	25	25	25	30	80	32